



# Wireless Temp and/or Humidity Transmitter with Setpoint & Override

## Installation and Operating Instructions

20357\_ins\_wireless\_temp\_xmtr\_set\_ovr

rev. 04/21/15

### Wireless System Overview

#### 418 MHz System:

The Transmitter measures the temperature or temp/humidity and transmits the data at 418MHz to the 418 MHz Receiver up to 100 feet away. The optional temperature setpoint and override status are also transmitted at 418 MHz to the receiver. The transmit rate is about once every 20 seconds with an estimated battery life of 5 to 8 years.

The information sent by the Transmitter is picked up by the 418 MHz Receiver and passed along to the Analog Output Modules. Each transmitted variable (temperature, humidity, setpoint, etc.) is converted by a separate output module into an analog resistance, voltage, current or relay contact which is hard wired to the analog inputs of the BAS controller.

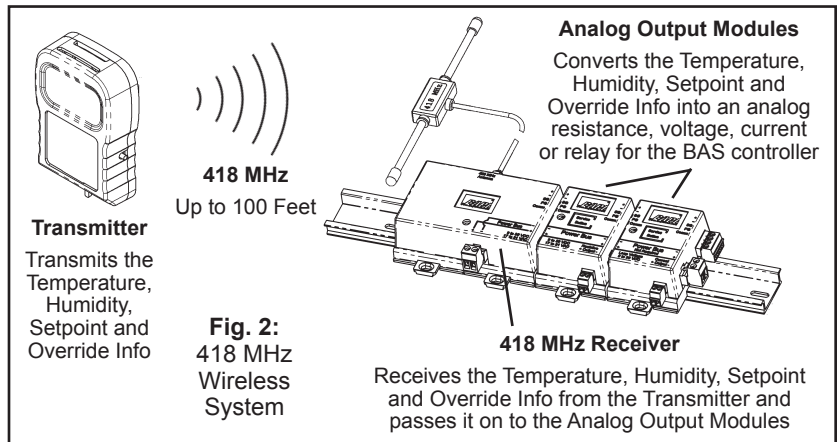

#### 900 MHz System:

The Transmitter measures the room temperature or temp/humidity and transmits the data at 418MHz to a Repeater up to 100 feet away. The optional temperature setpoint and override status are also transmitted at 418 MHz to the Repeater. The transmit rate is approximately once every 20 seconds with an estimated battery life of 5 to 8 years.

The 418 MHz information sent by the Transmitter is picked up by the Repeater and then Re-Transmitted at 900 MHz to a 900 MHz Receiver up to 1,000 feet away. The 900 MHz receiver picks up the information from the repeater and then passes it along to the Analog Output Modules. Each transmitted variable (temperature, humidity, etc.) is converted by a separate output module into an analog resistance, voltage, current or relay contact which is hard wired to the analog inputs of the BAS controller.

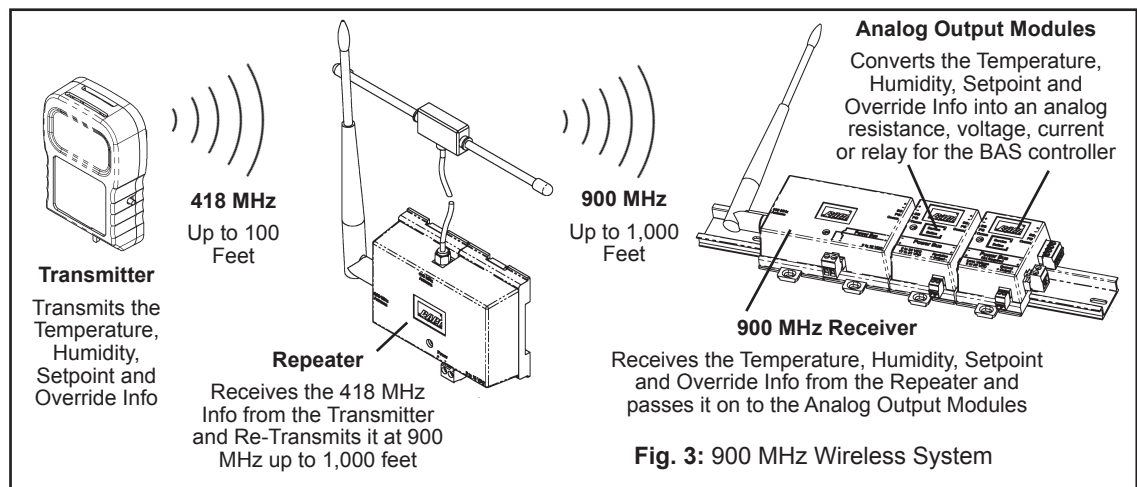

### Wireless Temperature and Humidity Transmitter Specifications

**Supply Power:** Two AA 3.6V Lith. batteries, 2.25 AH  
5 to 8 year battery life at 20 second transmit rate

#### Potential Inputs:

Temperature – Thermistor • Relative Humidity – Capacitive  
Setpoint – Potentiometer • Override – SPST switch

**Accuracy:**  $\pm 0.54^{\circ}\text{F}$  ( $\pm 0.3^{\circ}\text{C}$ ) /  $\pm 2\%$  RH

**Transmitted Range:** -40 to 185°F (-40 to 85°C) • 0-100% RH

**Antenna:** Built inside the enclosure

#### Environmental Operation Range:

Temp: 32° to 140°F (0° to 60°C)  
Humidity: 5 to 95% RH non-condensing

#### Enclosure Material & Rating:

ABS Plastic, UL94 V-0

#### Radio Frequency:

418 MHz North America

#### Transmitter Interval:

~20 seconds

**Fig. 3:**  
Wireless Transmitter Dimensions

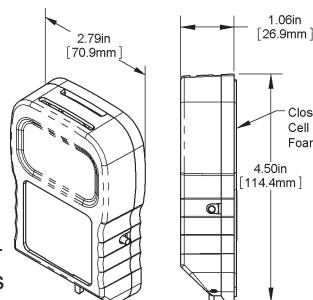

#### FCC Approval #:

T4F061213RSO (418MHz Room Transmitter Only)  
T4F060811TEMP (418MHz Temperature Probe Only)  
T4F060811RH (418MHz Temp & Humidity Probe Only)  
OUR9XSTREAM (Repeater Unit Only)

**Compliance:** This device complies with Part 15 of the FCC rules Operation is subject to the following conditions.

1. This device may not cause harmful interference.
2. This device must accept any interference received, including interference that may cause undesired operation.

#### FCC Radio Frequency Interference Statement:

This equipment has been tested and found to comply with the limits for a Class B digital device, pursuant to Part 15, Subpart B, of the FCC Rules. This equipment generates, uses, and can radiate radio frequency energy. If not installed and used in accordance with the instructions, it may cause interference to radio communications.

Specifications subject to change without notice.

### Analog Output Module Training

The installation process requires that each transmitter is trained to its associated output modules so that they communicate with each other. Pushing buttons in a defined sequence on the units will bind them together.

The training process is easiest on a test bench with the units within arm's reach of each other. Training can be done in the field but requires two people and a set of walkie talkies or cell phones. Be sure to place an identification mark on the transmitter and associated output modules after they have been trained so that they can be matched together at the job site.

If more than one variable is transmitted by the transmitter (temperature, humidity and setpoint for instance), each variable requires a separate output module. Perform the training sequence for each output module. Any transmitted variable can be trained to more than one output module. If a Repeater is used in the system, be sure it is powered and within reception range of the transmitter and the 900 MHz Receiver to train the output modules.

### TEMPERATURE OR HUMIDITY VARIABLE TRAINING

1. To train an output module to a temperature or humidity variable, select the Resistance, Voltage or Current Output Module calibrated to the proper temperature or humidity range and connect it to the wireless receiver. Note: Multiple output modules can be trained to the same transmitter variable if desired.
  2. Apply power to the receiver which will supply power to the connected output modules. The power LED on the receiver will light and remain lit. **(Current Output Modules must have loop power supplied to the module itself before they can be trained.)**
  3. Remove the cover of the room transmitter and remove the battery tabs or install the batteries, observing polarity as shown in Fig 4. The "transmit LED" will flash about once every 20 seconds, indicating a transmission. (The flash is very quick.)
  4. Press and hold down the "Service Button" on the top of the output module (Fig 5) that you wish to train. Then, press and release the "training button" (see Fig 4) on the transmitter. When the output module receives the "training transmission" from the transmitter, the output module's red LED will light steady. Release the "Service Button" on the output module and the red LED will go out. The transmitter and output module are now trained to each other. During normal operation, the output module's LED will flash about once every 20 seconds indicating data reception from the transmitter trained to it.
- Note:** Combination transmitters send both the temperature and humidity information when the "Training Button" is pressed. However, each Analog Output Module is configured at the time of order as a temperature, humidity, setpoint or override module and will only recognize the relevant information and will ignore the rest.
5. Mount the transmitter at the desired location, removing the batteries if needed. (The units will remain trained to one another through power failures and battery replacement.)

### SETPOINT VARIABLE TRAINING

1. To train an output module to a Setpoint variable, select the Setpoint Output Module (SOM) calibrated to the proper setpoint range and connect it to the wireless receiver. Note: Multiple output modules can be trained to the same transmitter variable if desired.
2. Apply power to the receiver which will supply power to the connected output modules. The LED on the Receiver will light and remain lit.
3. Remove the cover of the room transmitter and remove the battery tabs or install the batteries, observing polarity as shown in Fig 4. The "transmit LED" will flash about once every 20 seconds, indicating a transmission. (The flash is very quick.)
4. Press and hold down the "Service Button" on the top of the output module (Fig 5). Then, press and release the OVERRIDE button on the transmitter (See Fig 4). (Note: If the unit was not ordered with an override function, then the OVERRIDE button will be shorter and will not extend outside the case but will still be accessible upon removing the

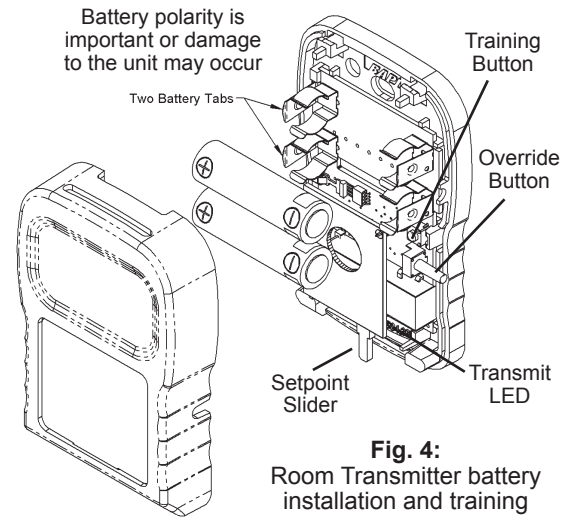

**Fig. 4:**  
Room Transmitter battery installation and training

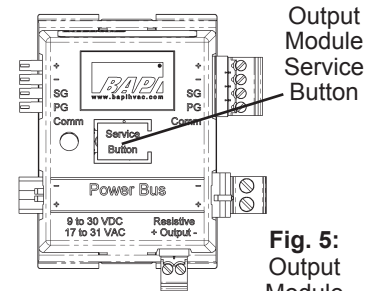

**Fig. 5:**  
Output Module

Continued on next page....

### Analog Output Module Training continued...

cover.) When the output module receives the “Training Setpoint” info from the transmitter, the output module’s red LED will light. Release the “Service Button” on the output module and the red LED will go out. The transmitter and output module are now trained to each other. During normal operation, the output module’s LED will flash about once every 20 seconds indicating data reception from the transmitter trained to it.

5. Mount the transmitter at the desired location, removing the batteries if needed. (The units will remain trained to one another through power failures and battery replacement.)

### VERRIDE TRAINING - OVERRIDE IN PARALLEL WITH THE TEMPERATURE VARIABLE

1. An Override function can be added to a Resistance Output Module or Voltage Output Module that has been previously trained to the Temperature variable. (Current Output Modules cannot be used with the override function.) Select the previously trained output module that will have the override function. Remove the cover by squeezing the top and bottom or using a flat screwdriver as shown in Fig 6. Place the module’s jumper J4 in the “Override Training ON” position as shown in Fig 7.
2. Apply power to the receiver which will supply power to the connected output modules. The power LED on the Receiver will light and remain lit.
3. Remove the room transmitter cover and remove the battery tabs or install the batteries, observing polarity as shown in Fig 4. The “transmit LED” will flash about once every 20 seconds, indicating a transmission. (The flash is very quick.)
4. Press and hold down the “Service Button” on the top of the output module (or on the circuit board if the cover is removed, see Fig 7). Then, press and release the OVERRIDE button on the room transmitter (See. Fig 3). When the output module receives the “Training Override” info from the transmitter, the output module’s red LED will light. Release the “Service Button” on the output module and the red LED will go out. This module is now trained to the override function on the room transmitter.
5. Return the jumper on J4 to the “Override Training OFF” position (Fig 7) and replace the output module’s cover. Pressing the override on the room transmitter will cause the Resistance Output Module output to go to less than 100 Ohms for 5 seconds or the Voltage Output Module output to go to 0 Volts for 5 seconds.
6. To remove the override function, retrain the module to the temperature variable (pg 2). This removes the override function.
7. Mount the transmitter at the desired location, removing the batteries if needed. (The units will remain trained through power failures and battery replacement.)

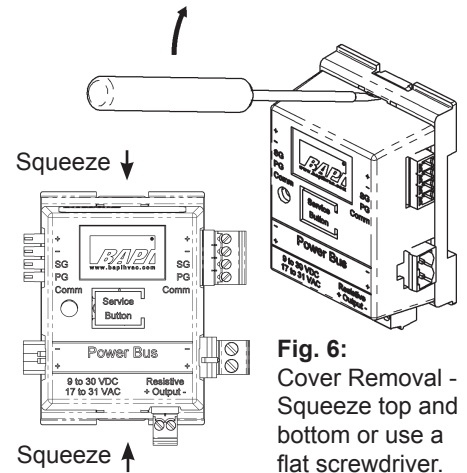

**Fig. 6:** Cover Removal - Squeeze top and bottom or use a flat screwdriver.

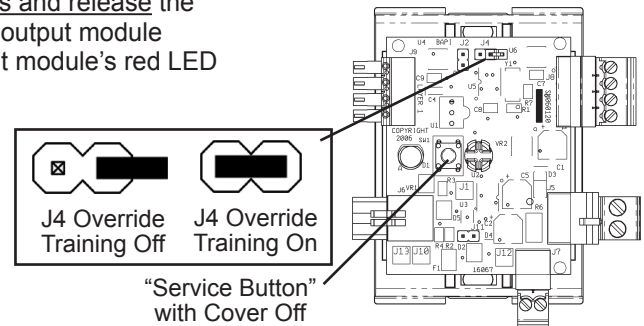

**Fig. 7:** Override Training Jumper Positions (J4) and “Service Button”

### VERRIDE TRAINING - OVERRIDE IN PARALLEL WITH HUMIDITY VARIABLE

1. An Override function can be added to a Voltage Output Module that has been previously trained to the Humidity variable. (Current Output Modules cannot be used with the override function.)
2. Apply power to the receiver which will supply power to the connected output modules. The power LED on the Receiver will light steady.
3. Remove the room transmitter cover and remove the battery tabs or install the batteries, observing polarity as shown in Fig 4. The small LED at the bottom right of the circuit board, next to the setpoint, will flash approximately once every 20 seconds indicating a transmission. (The flash is very quick.)

*Continued on next page....*

**Analog Output Module Training continued...**

4. Press and hold down the “Service Button” on the top of the Voltage Output Module. Then, press and release the OVERRIDE button on the room transmitter (See. Fig 4). When the output module receives the “Training Override” info from the room transmitter, the output module’s red LED will light. Release the “Service Button” on the output module and the red LED will go out. This output module is now trained to the override function on the room transmitter Pressing the override button on the room transmitter will cause the Voltage Output Module output to go to 0 Volts for 5 seconds.
5. To remove the override function, retrain the module to the humidity variable. This removes the override function.
6. Mount the transmitter at the desired location, removing the batteries if needed. (The units will remain trained to one another through power failures and battery replacement.)

**VERRIDE TRAINING - OVERRIDE AS A SEPARATE OUTPUT WITH A RELAY OUTPUT MODULE (RYOM MODEL ONLY)**

1. To train a Relay Output Module (RYOM model only) to the Override function, connect the output module to the receiver.
2. Apply power to the receiver which will power the connected output modules. The power LED on the Receiver will light and remain lit.
3. Remove the room transmitter cover and remove the battery tabs or install the batteries, observing polarity as shown in Fig 4. The small LED at the bottom right of the circuit board, next to the setpoint (see Fig 4), will flash approximately once every 20 seconds indicating a transmission. (The flash is very quick.)
4. Press and hold down the “Service Button” on the Relay Output Module (Fig 5). Then, press and release the OVERRIDE button on the room transmitter. When the output module receives the “Training Override” info from the room transmitter, the output module’s red LED will light. Release the “Service Button” on the output module and the red LED will go out. This Relay Output Module is now trained to the override function on the room transmitter.
5. Pressing the override button on the room transmitter will cause the output of a “Momentary” Relay Output Module to switch states for 5 seconds — the output of a “normally open” version will go to closed for 5 seconds, the output of a “normally closed” version will go to open for 5 seconds.
6. Mount the transmitter at the desired location, removing the batteries if needed. (The units will remain trained to one another through power failures and battery replacement.)

**Mounting of the Room Transmitter**

**Note:** The transmitter should already be trained to the output modules.

**Drywall Mounting**

1. Place the base plate against the wall where you want to mount the sensor. Typically 5 feet above the floor.
2. Using a pencil, mark out the two mounting holes.
3. Drill two 3/16” (4.7 mm) holes in the center of each marked mounting hole. Insert a drywall anchor into each hole.
4. Secure the base to the drywall anchors using the #6 x 1 inch mounting screws provided.
5. Install provided batteries or pull battery tabs and follow polarity as shown in figure 3 or damage may occur. The unit will work on just one battery however the battery life will be cut in half.
6. Attach cover by latching it to the top of the base, rotating the cover down and snapping it into place.
7. Secure the cover by backing out the lock-down screws using a 1/16” Allen wrench until they are flush with the bottom of the cover.

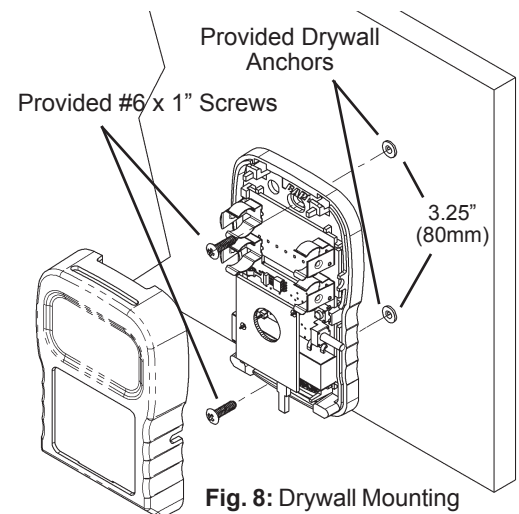

### 418 MHz Receiver and 900 MHz Receiver with Analog Output Modules Termination

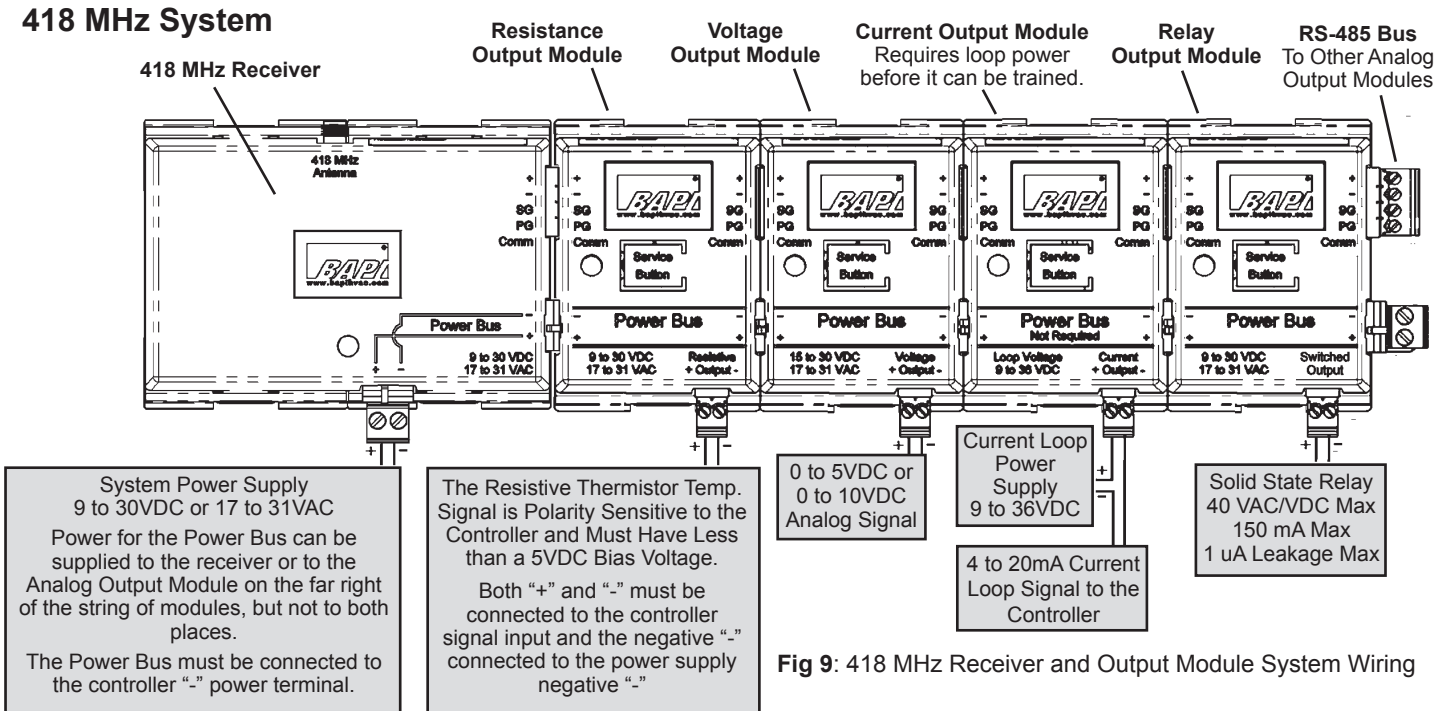

#### Termination Notes for 418 MHz and 900 MHz Systems:

1. The wireless receiver and Analog Output Modules are interconnected and require module power along the "Power Bus" terminals. The bus can be powered from either the receiver end on the left or the last output module on the right side. Be sure you have enough DC current or AC VA for all the devices on the bus.
2. The **Current Output Module (BA/COM)** signal is **LOOP POWERED** and must be externally powered with 9 to 36 VDC separate from the Power Bus. The Loop Power must be connected to the Current Output Module before it can be trained.
3. Be sure to follow the polarity (+ or -) symbols listed on each receiver and the output modules to maintain communication and Power Bus integrity.

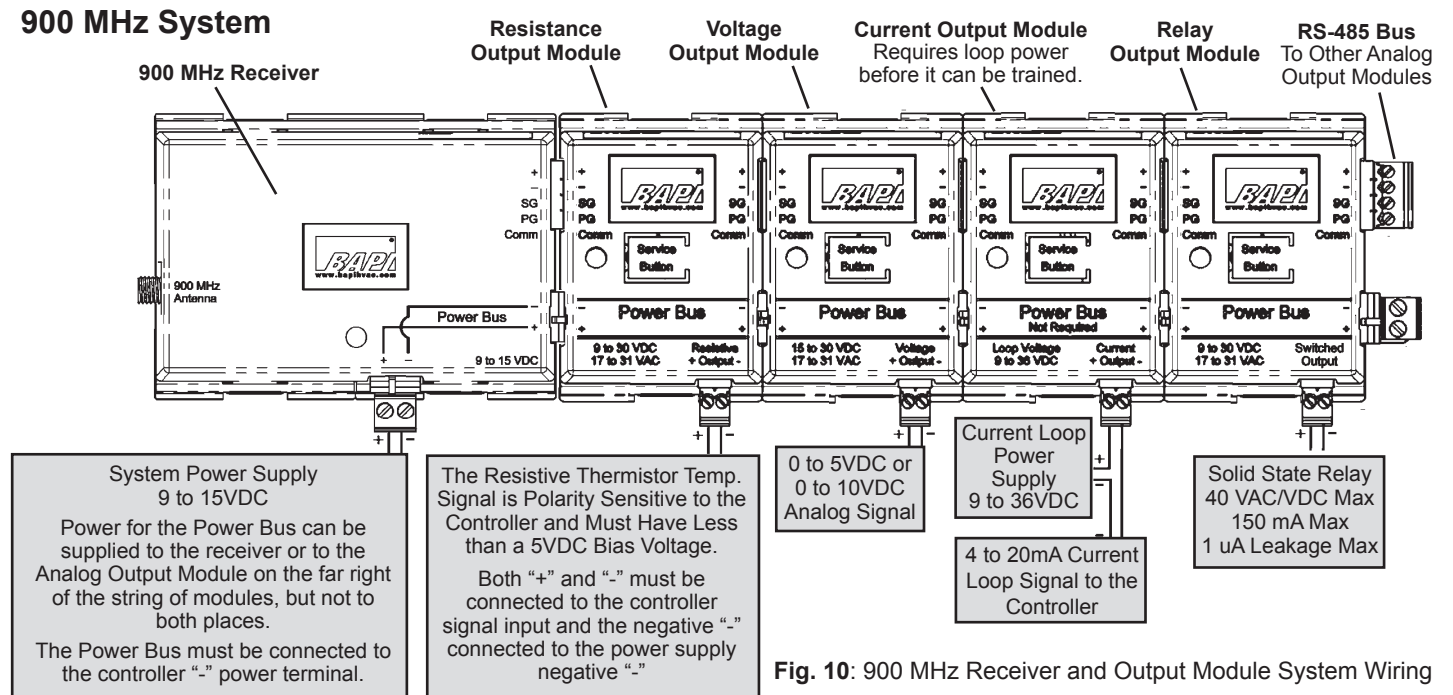

Specifications subject to change without notice.

### Extending the RS485 Network between the Receiver and the Analog Output Modules

The Analog Output Modules may be mounted up to 4,000 feet away from the Receiver. The total length of all the shielded, twisted pair (TSP) cables shown in Fig. 11 is 4,000 feet (1,220 meters), and "T" taps are not allowed. Connect the terminals as shown in Fig. 11. BAPI's VC350A EZ Voltage Converter and a small transformer can be used to power the group of Analog Output Modules.

\*If the distance from the receiver to the group of Analog Output Modules is greater than 100 feet (30 meters), provide a separate power supply for that group of Modules and install a 120Ω load resistor (1/4 watt) across the "+" and "-" communication terminals.

120Ω load resistor (1/4 watt) across the "+" and "-" communication terminals. See Asterisk (\*) above.

**Note:** This configuration requires one or more Pluggable Terminal Block Kits for the extra wire terminations on the left and right side of the Analog Output Modules. Each kit includes 4 connectors.

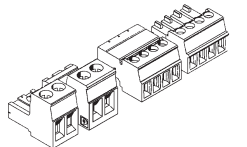

Pluggable Terminal Block Kit (BA/AOM-CONN)

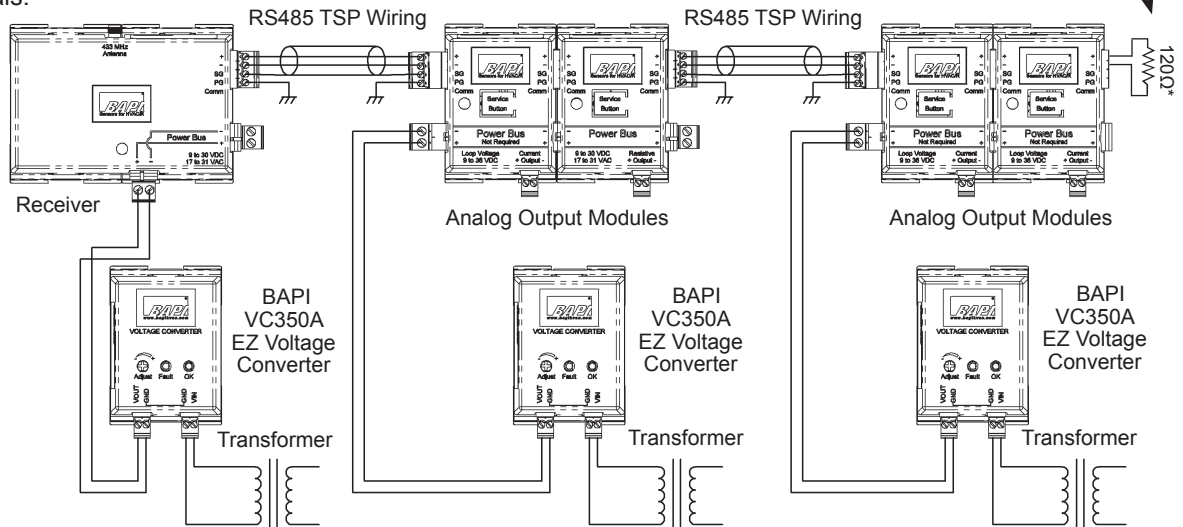

**Fig. 11:** Extended RS485 Network between the Receiver and the Analog Output Modules

### Wireless System Diagnostics

#### Possible Problems:

Temperature or Humidity is reading its low limit or high limit, or the LED at the top of the Analog Output Module is blinking rapidly:

Temperature or Humidity reading is coming out the wrong output module

Temperature or Humidity reading is incorrect

#### Possible Solutions:

- Check for proper wiring and connections from the output modules to the controller.
- Check to see if the controller's software is configured properly.
- Check for proper power to the receiver, repeater (if used) and output modules.
- Retrain the Analog Output Module.
- Check that the associated transmitter is transmitting (the LED will flash about once every 20 seconds when it transmits). If not, replace the batteries. Check that the associated receiver is receiving the transmissions (its LED will blink right after the transmitter LED if it receives that transmission.) If it is not receiving the transmissions, move it closer to the transmitter or reposition the antenna for maximum reception. **Note:** The receiver will receive transmissions from all transmitters that are within range, not just the one you are testing.
- Retrain the Analog Output Module.
- Check for proper wiring and connections from the output modules to the controller, and check to see if the correct output module is connected to the correct controller.
- Check to see if the controller's software is configured properly.

#### Analog Output Module Default Status when Wireless Transmission is Interrupted:

If an output module does not receive data from its assigned transmitter for 15 minutes, the red LED on the top of the module will blink rapidly. If this happens, the individual Analog Output Modules will react as follows:

- Resistance Output Modules (BA/ROM) calibrated for temperature will output the highest resistance in their output range.
- Voltage Output Modules (BA/VOM) calibrated for temperature will set their output to 0 volts.
- Current Output Modules (BA/COM) calibrated for temperature will set their output to 4 mA.
- Voltage Output Modules (BA/VOM) calibrated for humidity will set their output to their highest voltage (5 or 10 volts).
- Current Output Modules (BA/COM) calibrated for humidity will set their output to 20 mA.
- Setpoint Output Modules (BA/SOM) will hold their last value indefinitely.
- Relay Output Modules (BA/RYOM Units Only) will go to their default state (example: open for a normally open unit).

When a transmission is received, the output modules will revert to normal operation in 60 seconds or less.

Specifications subject to change without notice.